

## 直装形 3 爪セレーテッドチャック<A 形> <JIS 規格主軸端用>

### WEDGE-HOOK type 3-JAW POWER CHUCK <JIS A SPINDLE MOUNTING>

A 形主軸端の旋盤にアダプタを使用することなく、直接取付けることができますので、チャックのオーバーハングが少なくなり、切削性能や機械寿命の向上に役立ちます。

Can be directly mounted to a lathe with type A spindle end without use of an adapter, minimizing chuck overhang and improving cutting performance and

仕様 Specifications	形式番号 Series number	H01MA					
		6S	(8S)	(10S)		(12S)	
		—	8	10		12	
		A5-J	A6-J	A6-J	A8-J	A8-J	
セレーションピッチ Serration pitch	mm	1.5	1.5	1.5		1.5	
JIS A 主軸端番号 JIS A Spindle No.		5	6	6	8	8	
爪のストローク(直径にて) Jaw movement (Dia)	mm	7	7	8.8		8.8	
プランジャストローク (シリンダストローク) (Cylinder stroke)	mm	15	20	25		25	
最大・最小把握径(外径) Recommended outside chucking diameter for standard soft blank jaws	最大 Max.	mm	165	210	254		304
	最小 Min.	mm	20	18	24		10
最高使用回転数 Max. Speed	r/min	4500	4000	3500		2800	
許容シリンダ力 Max. input force	kN	14.7	24.5	30.4		39.2	
把握力 Clamping force at Max. input force (Total jaw force)	kN	41.2	67.7	94.1		124	
慣性モーメント Moment of inertia J	注1 Note1	kg·m <sup>2</sup>	0.045	0.14	0.26	0.33	
質量 Weight with standard soft blank jaws		kg	13	25	34.5	41	
対応シリンダ Matching cylinder							
HH4C	形式番号 Series number		※ 100	※ 125	125	※ 140	
	最高使用圧力 Max. pressure to operate chuck	MPa	2.1	2.2	2.7	2.8	
H05CH	形式番号 Series number		175	※ 250	250	※ 300	
	最高使用圧力 Max. pressure to operate chuck	MPa	0.6	0.5	0.6	0.6	

注: 1. この値の 4 倍が GD<sup>2</sup> に相当します。

- ※印の回転シリンダはストローク規制が必要です。
- 回転シリンダの最高回転数が低い場合には、その回転数に合わせてください。
- 把握爪の寸法は標準生爪寸法表を参照願います。

Note: 1. The four times of this value is equivalent to GD<sup>2</sup>.

- If the plunger stroke of a chuck is shorter than that of a cylinder, the latter must be adjusted to the former. The cylinders of model marked ※ are required limiting of stroke.
- When the Max. speed of a rotating cylinder is lower than that of a chuck, observe that of a rotating cylinder.
- The dimensions of top jaws are on the pages of "Standard soft blank jaw".

記号 Symbol	形式番号 Series number	H01MA					
		6S	(8S)	(10S)		(12S)	
		—	8	10		12	
		A5-J	A6-J	A6-J	A8-J	A8-J	
JIS A 主軸端番号 JIS A Spindle No.		5	6	6	8	8	
<b>A</b>		165	210	254		304	
<b>B</b>		140	180	180	225	210	
<b>C</b>		82.563	106.375	106.375	139.719	139.719	
<b>D</b>		16	18	18	20	20	
<b>E</b>		80	100	110		125	
<b>F</b>		104.8	133.4	133.4	171.4	171.4	
<b>G</b>		M10	M12	M12	M16	M16	
<b>H</b>		13	15	18	22	22	
<b>J</b>		M16 ×2	M20 ×2.5	M20 ×2.5		M24 ×3	
<b>J1</b>		31	34	40		50	
<b>K</b>		36	36	36		46	
<b>L</b>	Max.	11.5	90	99		117	
	Min.	-3.5	70	74		92	
<b>M</b>		—	28	34		39	
<b>M</b>	Max.	—	28	36		40	
<b>N</b>	Serr. Pitch 1.5	Max.	41.1	40.1	46.3	49.75	
		Min.	37.6	36.6	41.9	45.35	
	Serr. Pitch 3	Max.	—	42.3	48.5		52
		Min.	—	38.8	44.1	47.6	
<b>O</b>	Serr. Pitch 1.5	Max.	14	29	39.75	54	
		Min.	7	14	15.75	18	
	Serr. Pitch 3	Max.	—	27	37.5		55
		Min.	—	12	13.5		16
<b>P</b>		5	5	5		5	
<b>S1</b>		52.4	66.7	66.7	85.7	85.7	
<b>S2</b>		16.3	19.45	19.45	24.2	24.2	
<b>S3</b>		6.5	6.5	6.5	8	8	
<b>W</b>		32	38	44		52	
<b>X</b>	Serr. Pitch 1.5	44	44	44		54	
	Serr. Pitch 3	—	43	43		53	

注: ( ) の形式は受注生産です。

Note: Parenthesized models are made to order.

### 形番表示方法 Model Coding

H01MA □ □ □ □

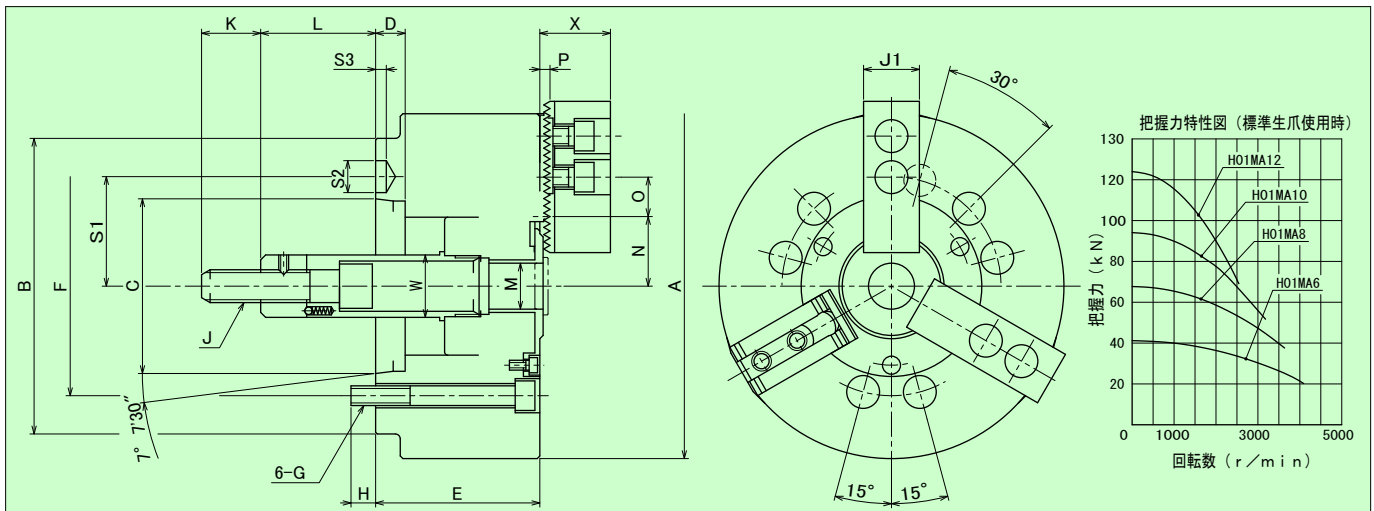
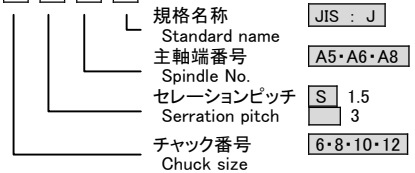

## 直装形 3 爪セレーテッドチャック<A 形> <JIS 規格主軸端用>

## WEDGE-HOOK type 3-JAW POWER CHUCK <JIS A SPINDLE MOUNTING>

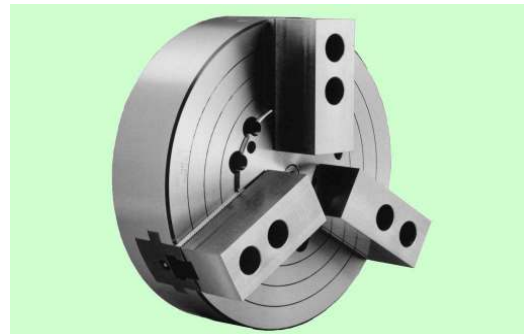

仕様 Specifications	形式番号 Series number	H01MA				
		15		18	21	24
		A8-J	A11-J	A11-J	A11-J	A11-J
JIS A 主軸端番号 JIS A Spindle No.		8	11	11	11	11
セレーションピッチ Serration pitch	mm	3	3	3	3	3
爪のストローク(直径にて) Jaw movement (Dia)	mm	18.6	18.6	18.6	18.6	18.6
プランジャストローク Plunger stroke (シリンダストローク) (Cylinder stroke)	mm	35	35	35	35	35
最大・最小把握径(外径) Recommended outside chucking diameter for standard soft blank jaws	最大 Max.	mm	381	457	530	610
	最小 Min.	mm	60	60	110	110
最高使用回転数 Max. Speed	r/min	2100	1700	1500	1200	
許容シリンダ力 Max. input force	kN	73.5	73.5	98.1	98.1	
把握力 Clamping force at Max. input force (Total jaw force)	kN	147	147	194	194	
慣性モーメント Moment of inertia J	注1 Note1	kg・m <sup>2</sup>	1.78	3.45	6.85	11.63
質量 Weight with standard soft blank jaws		kg	98	132	195	250
対応シリンダ Matching cylinder						
HH4C	形式番号 Series number		200	200	200	200
	最高使用圧力 Max. pressure to operate chuck	MPa	2.5	2.5	3.3	3.3

- 注: 1. この値の 4 倍が GD<sup>2</sup> に相当します。  
 2. 回転シリンダの最高回転数が低い場合には、その回転数に合わせてください。  
 3. 把握爪の寸法は標準生爪寸法表を参照願います。  
 Note: 1. The four times of this value is equivalent to GD<sup>2</sup>.  
 2. When the Max. speed of a rotating cylinder is lower than that a chuck, observe that of a rotating cylinder.  
 3. The dimensions of top jaws are on the pages of "Standard soft blank jaw".

記号 Symbol	形式番号 Series number	H01MA				
		15		18	21	24
		A8-J	A11-J	A11-J	A11-J	A11-J
JIS A 主軸端番号 JIS A Spindle No.		8	11	11	11	11
A		381	457	530	610	
B		225	280	280	280	280
C		139.719	196.869	196.869	196.869	196.869
D		20	20	20	20	20
E		125	125	140	140	
F		171.4	235	235	235	235
G		M16	M20	M20	M20	M20
H		22.5	26	26	31	31
J		M27 × 3		M27 × 3	M30 × 3.5	M30 × 3.5
J1		65	65	65	65	65
K		50	50	55	55	55
L	Max.	35	35	35	35	
	Min.	0	0	0	0	
N	Max.	74.5	74.5	101.5	101.5	
	Min.	65.2	65.2	92.2	92.2	
O	Max.	54.5	90.5	100.5	136.5	
	Min.	18	18	18	18	
P		10	10	10	10	
R		30°	30°	30°	30°	
S1		85.7	117.5	117.5	117.5	117.5
S2		24.2	29.4	29.4	29.4	29.4
S3		8	10	10	10	10
T1		175	175	220	220	
T2		7	7	7	7	
W		63	63	75	75	
X		78	78	78	78	

### 形番表示方法 Model Coding

